

TECHNICAL DATA

Pump battery		P 2023	P 2025	P 2525
Max. theor. output	m ³ /h	164	163	164
Max. number of strokes	min.	32	27	22
Max. concrete pressure	bar	85	85	85
Placing boom		39 R		
Delivery line diameter		DN 125		
Length of end hose	m	3,0		
Vertical reach	m	38,70		
Horizontal reach	m	34,65		
Number of articulations		4		
Height of articulations	m	4,1 / 13,4 / 21,80 / 30,1		
Slewing range		2 x 370°		
Outrigger load, front	kN	180		
Outrigger load, rear	kN	180		

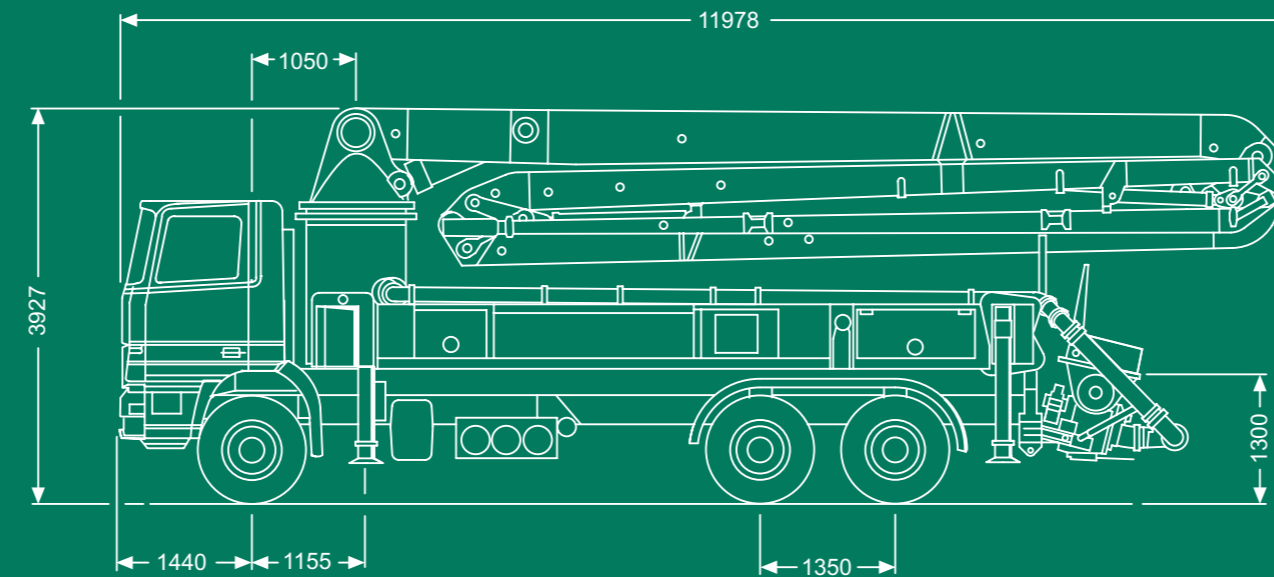

TRUCK-MOUNTED CONCRETE PUMP S 39 SX

WORKING RANGE

S 39 SX

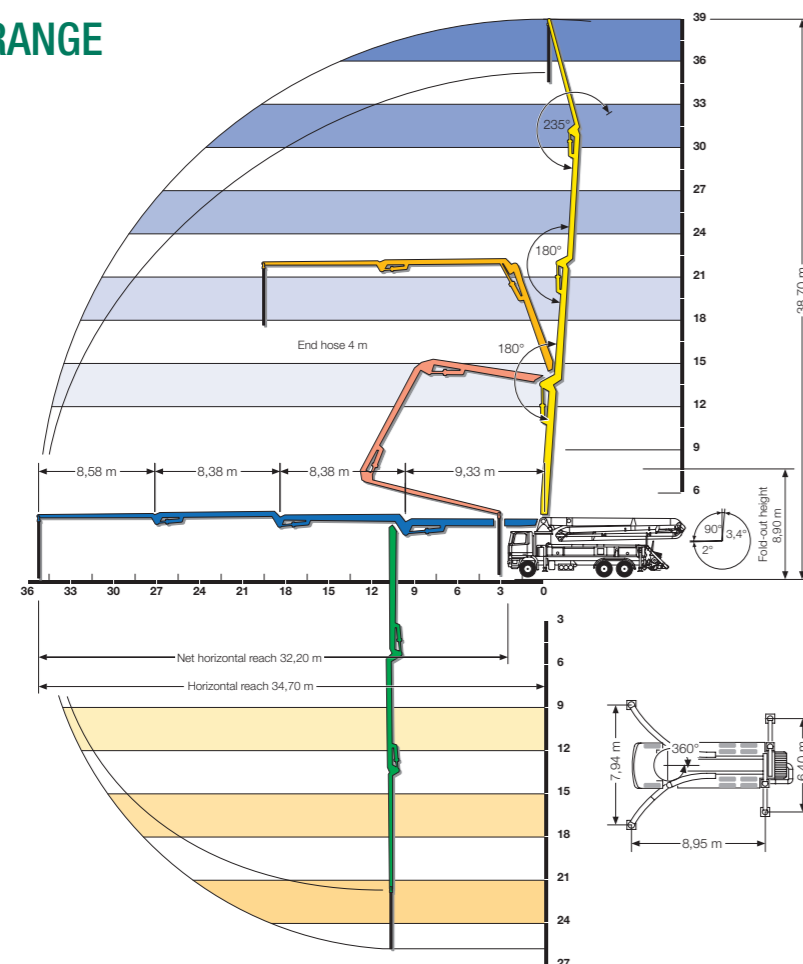

SCHWING-STETTER MOVES CONCRETE. WORLDWIDE.

Wherever concrete is produced and moved is where you will find Schwing-Stetter machinery.

With plants in Germany, Austria, USA, Brazil, Russia, China and India as well as with more than 100 sales and service facilities, the group of companies is always close to the customer.

Our wide range of products with something for every application is what makes Schwing-Stetter the No. 1 system supplier for concrete machinery worldwide.



SCHWING GMBH
P.O. Box 20 03 62 · D-44647 Herne / Germany
Phone (0) 23 25 / 9 87-0 · Fax (0) 23 25 / 7 29 22
www.schwing.de · info@schwing.de

Subject to modifications in the interest of technical progress. The exact standard scope of delivery is detailed in the offer.

10311.056.2000.04.10SK

SCHWING GmbH
Heerstrasse 9-27
44653 Herne, Germany
Phone +98 021 - 224 286 75-8
Fax +98 021 - 224 286 78
@mr.pump_iran
www.saghargostar-co.ir



SCHWING TRUCK-MOUNTED CONCRETE PUMP S 39 SX

THE ALL - ROUNDER ON 3 AXLES

This highly versatile truck-mounted pump covers a broad range of applications, offering you a three-axle machine with a vertical reach of almost 40 m.

Particularly pump services with smaller vehicle fleets and ready-mix companies appreciate the advantages of this all-purpose performer.

With an overall length of less than 12 m and a weight of under 26 t, this vehicle does not require any special permits. The combination of front Super X-outriggers and rear H-outriggers makes for short setup times and a minimum footprint

The S 39 SX occupies an operating footprint that is around 80 % smaller compared to ordinary machines with space-hogging rear folding outriggers. The outrigger cylinders are housed in square tubes, so they are not subjected to any buckling forces. The turret provides the operator with optimum access to the pipeline.

SCHWINGS specially developed anti-torsion frame forms the substructure for this machine as well;

in this advanced design, the supporting forces are transferred to the horizontal holding boxes directly at the corner points of the frame. Compared to other concepts with a trestle frame, this design ensures absolutely smooth operation during pumping, even in the rear area of the machine.

With the S 39 SX with hanging end hose, the operator can pour concrete from the maximum range right up to the bumper. Additionally, the hose is caught automatically when the boom is folded. It is not necessary to extend the boom, as in conventional Z-folding systems. External knuckle levers and the box section boom complete this supremely practical concept.

All on board tanks are designed for maximum capacity.

The water tank holds 600 l. The hydraulic tank with 600 l capacity extends the service life of the oil.

The deployment of the long-stroke 2525 pump kit in conjunction with the Big Rock Valve enables this machine to pump even difficult concrete grades with no problems, ensuring minimum wear and maximum running smoothness. Just 13 strokes per minute are all it takes to pump 100 m³/h.

And as in all SCHWING machines, the Rock Valve ensures excellent suction and pumping performance, high economy, low wear and exceptional dependability.

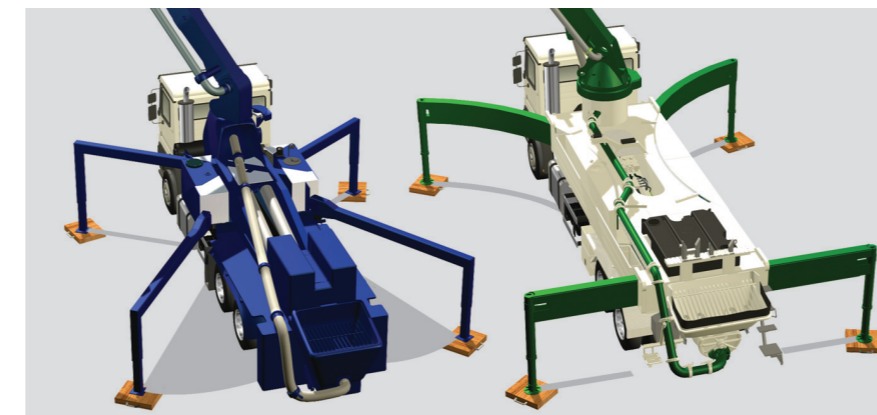

Due to the combination of front X and rear H outriggers the S 34 X can set up without the space hogging footprints of the other outrigging systems.



The orderly rear area with the 600 l water tank ensures good accessibility.

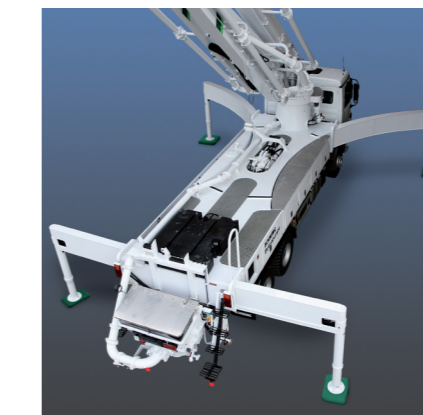

The combination of long stroke pump kit and Rock Valve ensures smooth running and easy delivery of even the most difficult grades at minimum wear.



The torsion resistant frame that transfers the outrigger forces directly to the corner points provides enough space for a 600l oil tank and room for hoses and pipes.

SCHWING GmbH
Heerstrasse 9-27
44653 Herne, Germ,any
Phone +98 021 - 224 286 75-8
Fax +98 021 - 224 286 78
@mr.pump_iran
www.saghargostar-co.ir